

SV08-47A Spool, 4-Way, 3-Position, Tandem Center

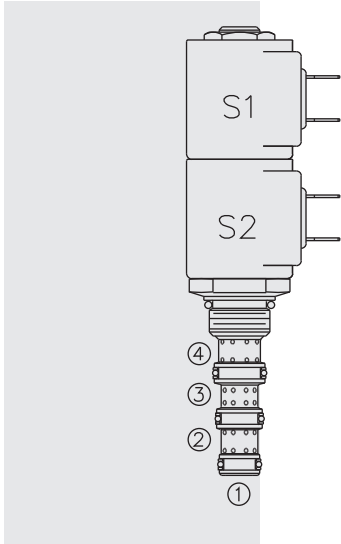

DESCRIPTION

A solenoid-operated, four-way, three-position, direct-acting, spool-type, tandem center, screw-in hydraulic cartridge valve.

OPERATION

When de-energized, the **SV08-47A** blocks cylinder ports, while allowing flow from 3 to 1. When coil #1 is energized, flow is allowed from 3 to 2, and from 4 to 1. When coil #2 is energized, flow is allowed from 3 to 4, and from 2 to 1.

In circuits where work port flows are unequal due to cylinder ratios, the higher return flow should be directed to port 2.

While 1 may be fully pressurized, it is not intended for use as the valve's inlet.

Operation of Manual Override Option: To override, push the knurled knob to activate the coil #2 (S2) function; pull the knob to activate the coil #1 (S1) function.

FEATURES

- Continuous-duty rated solenoid.
- Hardened precision spool and cage for long life.
- Optional coil voltages and terminations.
- Efficient wet-armature construction.
- All ports may be fully pressurized.
- Cartridges are voltage interchangeable.
- Unitized, molded coil design.
- Manual override option.
- Optional waterproof E-Coils rated up to IP69K.

RATINGS

Operating Pressure: 210 bar (3000 psi)

Flow: 11.4 lpm (3.0 gpm) max.

Internal Leakage: 278 cc/minute (17 cu. in./minute) max. at 207 bar (3000 psi)

Temperature: -40 to 120 °C with standard Buna seals

Coil Duty Rating: Continuous from 85% to 115% of nominal voltage

Initial Coil Current Draw at 20 °C: Standard Coil: 1.2 A at 12 Vdc; 0.13 A at 115 Vac (full wave rectified). E-Coil: 1.4 A at 12 Vdc; 0.7 A at 24 Vdc

Minimum Pull-in Voltage: 85% of nominal at 207 bar (3000 psi)

Filtration: See page 9.010.1

Fluids: Mineral-based or synthetics with lubricating properties at viscosities of 7.4 to 420 cSt (50 to 2000 sus); See Temperature and Oil Viscosity, page 9.060.1

Installation: No restrictions; See page 9.020.1

Cavity: VC08-4; See page 9.108.1

Cavity Tool: CT08-4XX; See page 8.600.1

Seal Kit: SK08-4X-MMM; See page 8.650.1

Coil Nut: Part No. 7004400; **Manual Override Coil Nut:** Part No. 4528180;

Coil Spacer: Std D-Coil Spacer Part No. 7012940; E-Coil Spacer Part No. 4534720; If cartridge is ordered "Less Coil," D-Coil spacer will be provided unless an E is specified in the Coil Termination To Order section.

SYMBOLS

USASI:

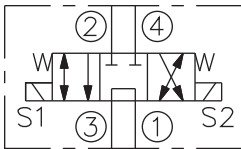

ISO:

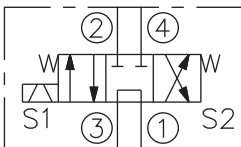

PERFORMANCE (Cartridge Only)

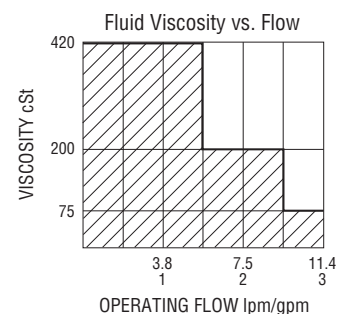
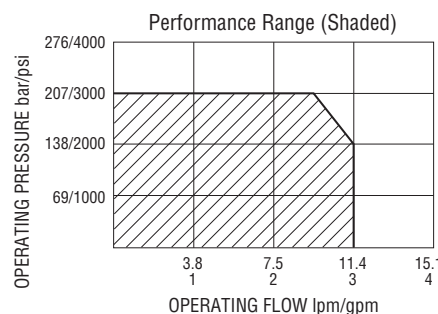
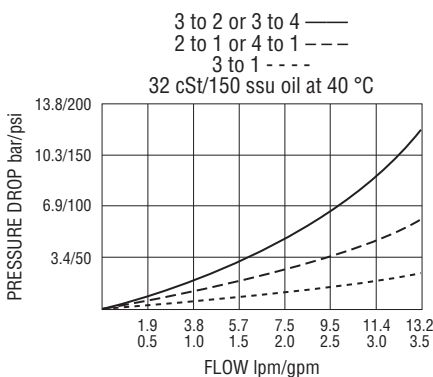

DIMENSIONS

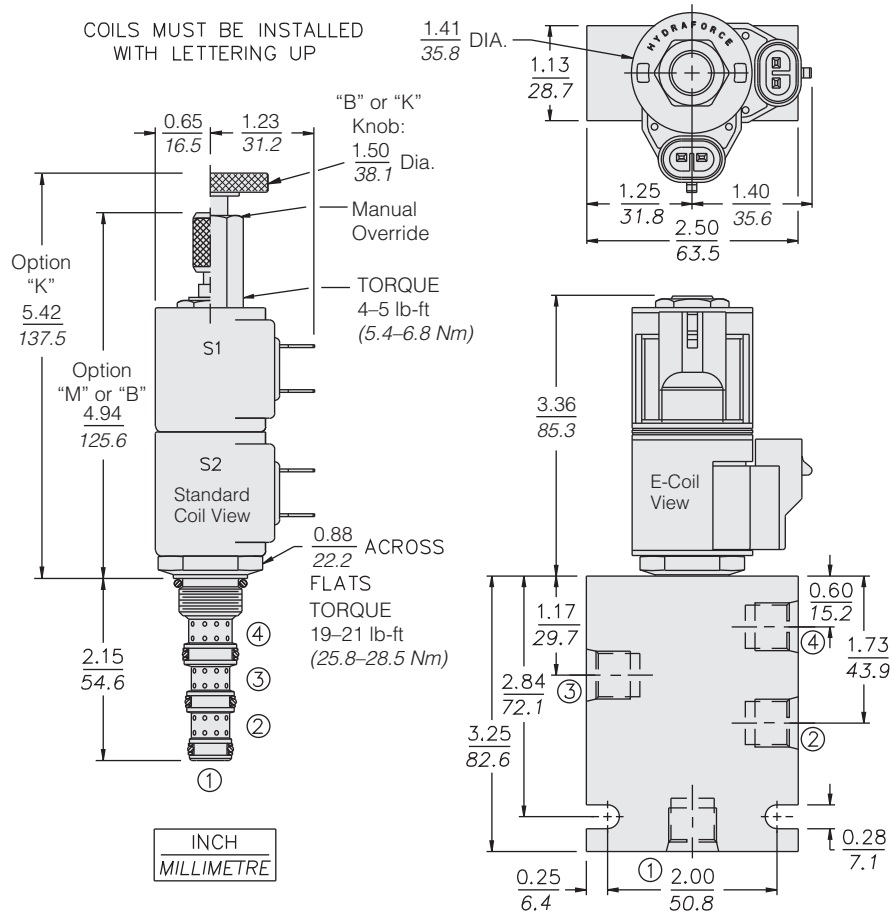

MATERIALS

Cartridge: Weight: 0.13 kg (0.28 lb); Steel with hardened work surfaces. Zinc-plated exposed surfaces; Buna N O-rings and back-ups standard.

Standard Ported Body: Weight: 0.27 kg (0.60 lb); Anodized high-strength 6061 T6 aluminum alloy, rated to 207 bar (3000 psi); Ductile iron bodies available; dimensions may differ. See page 8.008.1.

Standard Coil: Weight each: 0.11 kg (0.25 lb); Unitized thermoplastic encapsulated, Class H high temperature magnet wire. See page 3.200.1

E-Coil: Weight: 0.14 kg (0.3 lb); Perfect wound, fully encapsulated with rugged external metal shell; **Rated up to IP69K with integral connectors. See page 3.400.1.**

TO ORDER

SV08-47A - - - - -

1,000 Hour Salt Spray Coating **G**

Option

None (Blank)

Manual Override **M**

Manual Override **B**

Manual Override **K**

For Manual Override options see page 1.001.1

Porting

Cartridge Only **0**

SAE 6 **6T**

3/8 in. BSP* **3B**

*BSP Body; U.K. Mfr. Only

Seals

Buna N (Std.) **N**

Fluorocarbon **V**

Voltage Std. D-Coil

00 Less Coil**

10 10 Vdc†

12 12 Vdc

20 20 Vdc

24 24 Vdc

36 36 Vdc

48 48 Vdc

24 24 Vac††

115 115 Vac††

230 230 Vac††

**Includes D-Coil Nut and Spacer.

† DS, DW or DL terminations only.

†† AC Volt Only

E-Coils: 10, 12, 20, 24 Vdc only.

Coil Termination

Less Coil w/Spacer **E**

Deutsch DT04-2P **ER** (IP69K)

Metri-Pack® 150 **EY** (IP69K)

Dual Lead Wires **EL** (IP69K)

Amp Jr. Timer **EJ** (IP67)

DIN 43650 **EG** (IP65)

Dual Spades **—**

DIN 43650 **—**

1/2" Conduit **—**

E-Coil

D-Coil

DR (IP65)

DY (IP65)

DL (IP65)

—

DG (IP65)

DS (IP65)

AG (IP65)††

AP (IP65)††

For Coils with Zener Diode, add "Z" to option code. For example: "ER/Z". Not available on all models. See coil option info. on pages 3.200.1 & 3.400.1